

# Design Techniques for EMC – Part 2

## Cables and Connectors

By Eur Ing Keith Armstrong CEng MIEE MIEEE  
Partner, Cherry Clough Consultants, Associate of EMC-UK

This is the second in a series of six articles on best-practice EMC techniques in electrical/electronic/mechanical hardware design. The series is intended for the designer of electronic products, from building block units such as power supplies, single-board computers, and “industrial components” such as motor drives, through to stand-alone or networked products such computers, audio/video/TV, instruments, etc.

The techniques covered in the six articles are:

- 1) Circuit design (digital, analogue, switch-mode, communications), and choosing components
- 2) Cables and connectors**
- 3) Filters and transient suppressors
- 4) Shielding
- 5) PCB layout (including transmission lines)
- 6) ESD, electromechanical devices, and power factor correction

A textbook could be written about any one of the above topics (and many have), so this magazine article format can do no more than introduce the various issues and point to the most important of the best-practice techniques. Many of the techniques described in this series are also important for improving signal integrity.

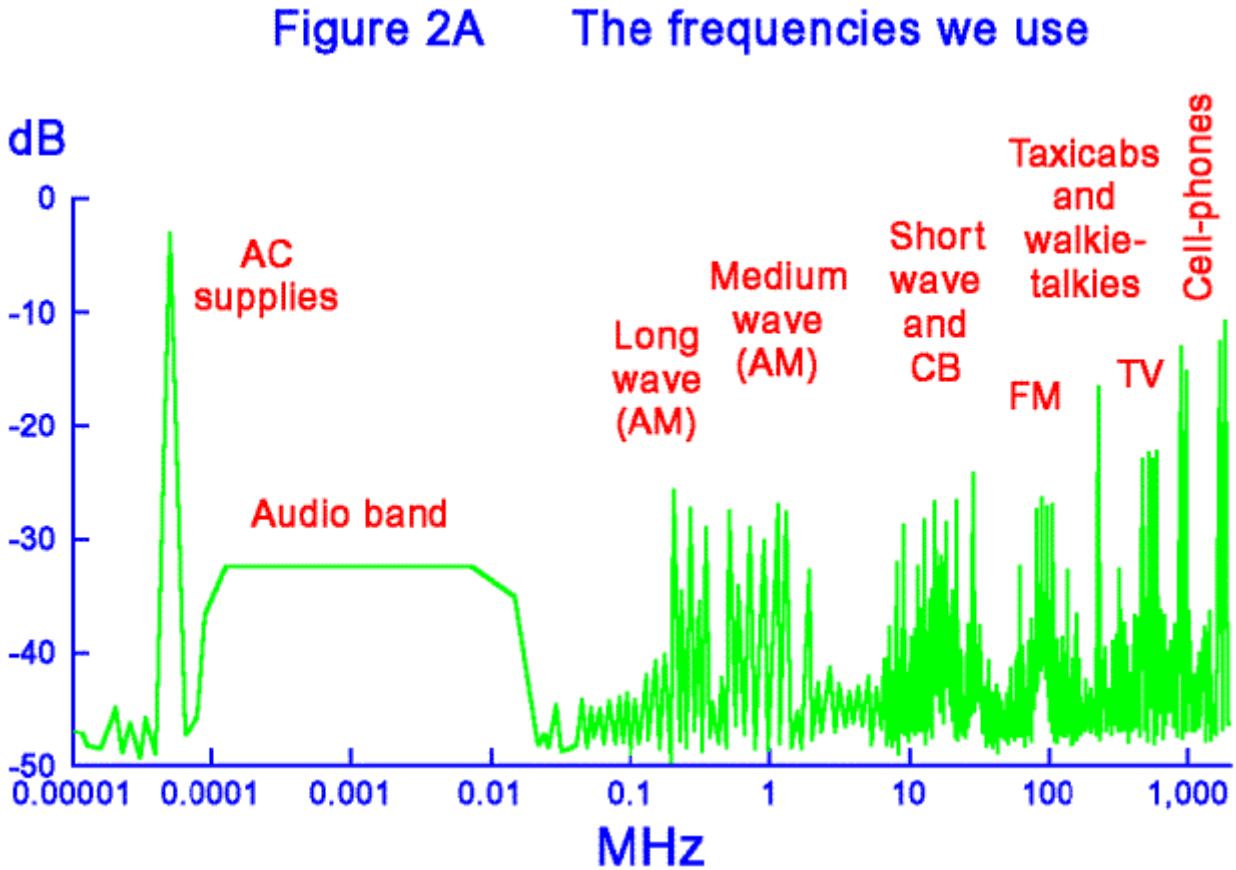
### Table of contents for this part

2. All cables are antennas
  - 2.1 Spectrum use and the possibilities for interference
  - 2.2 Leakage and antenna effect of conductors
  - 2.3 All cables suffer from intrinsic resistance, capacitance, and inductance
  - 2.4 Avoiding the use of conductors
    - 2.4.1 Cost/benefit analyses of alternatives to conductors
  - 2.5 Cable segregation and routing
  - 2.6 Getting the best from cables
    - 2.6.1 Transmission lines
    - 2.6.2 EMC considerations for conductors used inside and outside products
    - 2.6.3 Pairing send and return conductors
    - 2.6.4 Getting the best from screened cables: the screen
    - 2.6.5 Getting the best from screened cables: terminating the screen
    - 2.6.6 Terminating cable screens at both ends
  - 2.7 Getting the best from connectors
    - 2.7.1 Unscreened connectors
    - 2.7.2 Connectors between PCBs
    - 2.7.3 Screened connectors
  - 2.8 Further reading

## 2. All cables are antennas

### 2.1 Spectrum use and the possibilities for interference

Figure 2A shows the frequencies in common use in civilian daily life, from AC powerlines through audio frequencies, long, medium, and short-wave radio, FM and TV broadcast, to 900MHz and 1.8GHz cellphones.

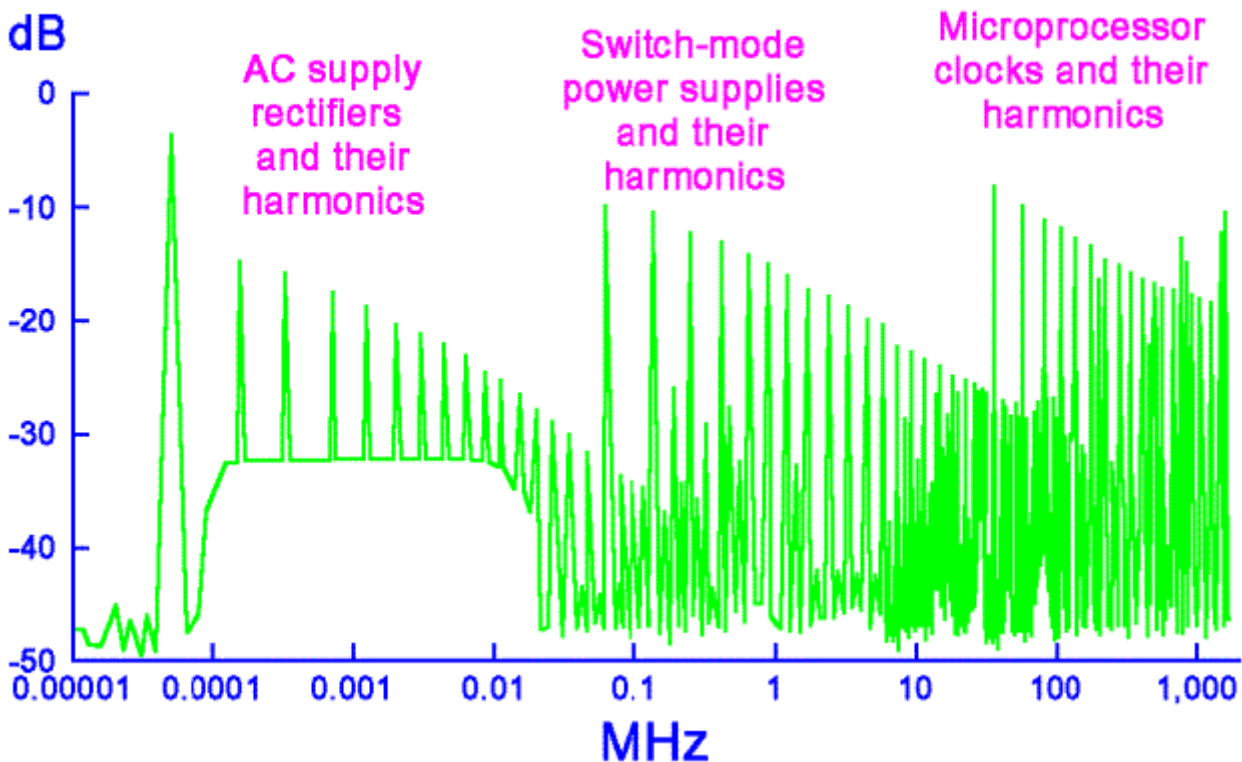


The real spectrum is busier than this – all of the range above 9kHz is used for something by someone.

This figure will soon need extending to 10 (or even 100GHz) as microwave techniques become more commonplace in ordinary life.

Figure 2B overlays the usage spectrum of Figure 2A with a less familiar spectrum showing the typical emissions from commonplace electrical and electronic equipment.

Figure 2B Plus the interference we create



AC mains rectifiers emit switching noise at harmonics of the fundamental to considerable frequencies, depending on their power.

A 5kVa or so power supply (whether linear or switch-mode) can fail conducted emissions limits up to several MHz due to the switching noise of its 50 or 60Hz bridge rectifier.

Thyristor-based DC motor drives and phase-angle AC power control will have similar emissions. These emissions can easily interfere with long and medium wave broadcasting, and part of the short-wave band.

Switch-mode power converters can operate at fundamental frequencies between 2 and 500kHz. It is not unusual for a switch-mode converter to have significant levels of emissions at 1,000 times its switching frequency. Figure 2B shows the emissions from a 70kHz switching power supply typical of a personal computer. These emissions can interfere with radio communications up to and including the FM broadcast band.

Figure 2B next shows the typical emissions spectrum from a 16MHz clocked microprocessor or microcontroller. It is not unusual for these commonplace items to exceed emissions limits at frequencies of 200MHz or more. As personal computers are now using 400MHz clocks and heading for 1GHz, it is obvious that digital technology is capable of interfering with (and being interfered with) all the upper range of our spectrum.

The reason for mentioning this is that *all conductors are antennas*. They all convert conducted electricity into electromagnetic fields, which can then leak out into the wider environment. They all convert electromagnetic fields in their locality into conducted electrical signals. There are no exceptions to this rule in our universe.

Conductors are thus the principal means by which signals cause radiated emissions, and by which external fields contaminate signals (susceptibility and immunity).

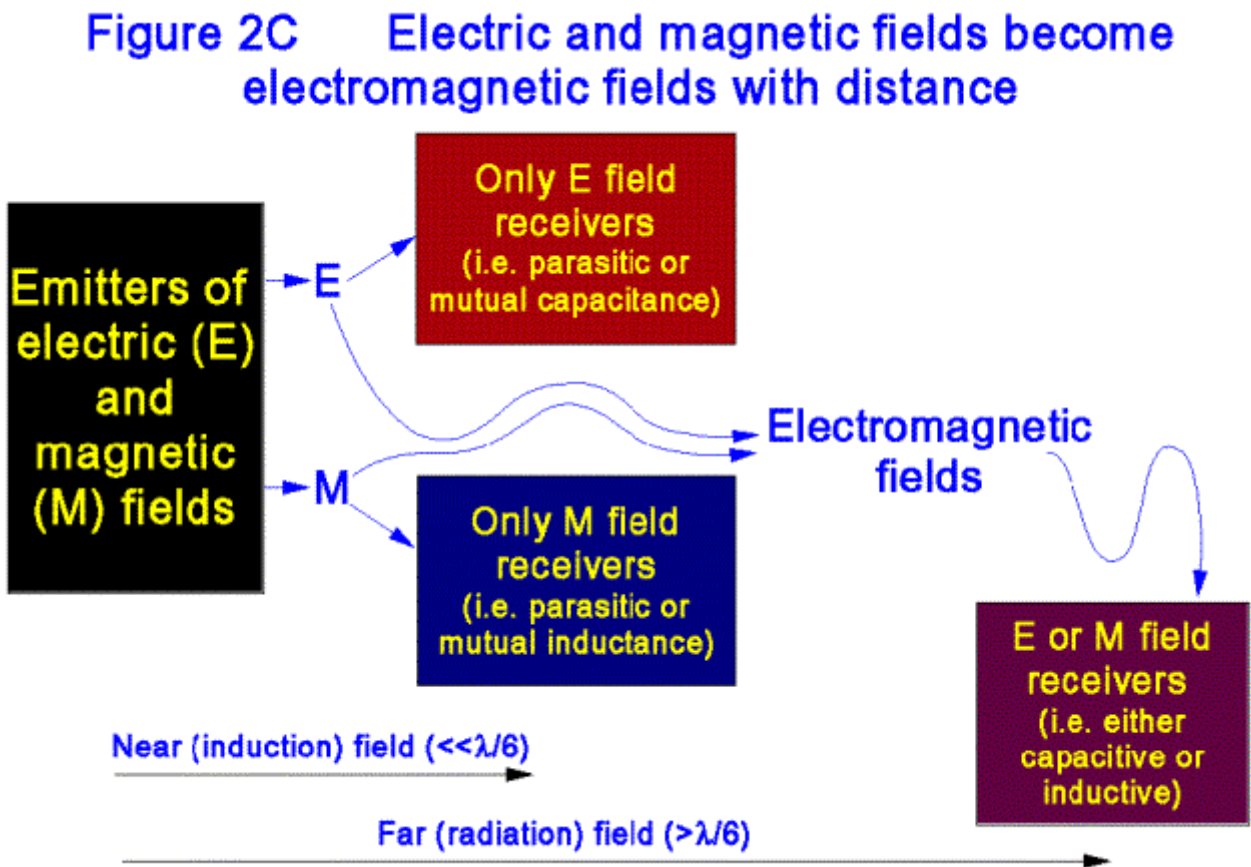
## 2.2 Leakage and antenna effect of conductors

Electric (E) fields are created by voltages on conductor areas, and magnetic (M) fields are created by currents flowing (in loops, as they always do). All electrical signals create both types of field with their conductors, so all conductors leak their signals to their external environment, and allow external fields to leak into their signals.

At distances greater than one-sixth of the wavelength ( $\lambda$ ) of the frequencies of concern, E and M fields develop into full electromagnetic (EM) fields with both electric and magnetic components.

For example: the transition to full EM fields occurs at 1.5 metres for 30MHz, 150mm for 300MHz, and 50mm for 900MHz.

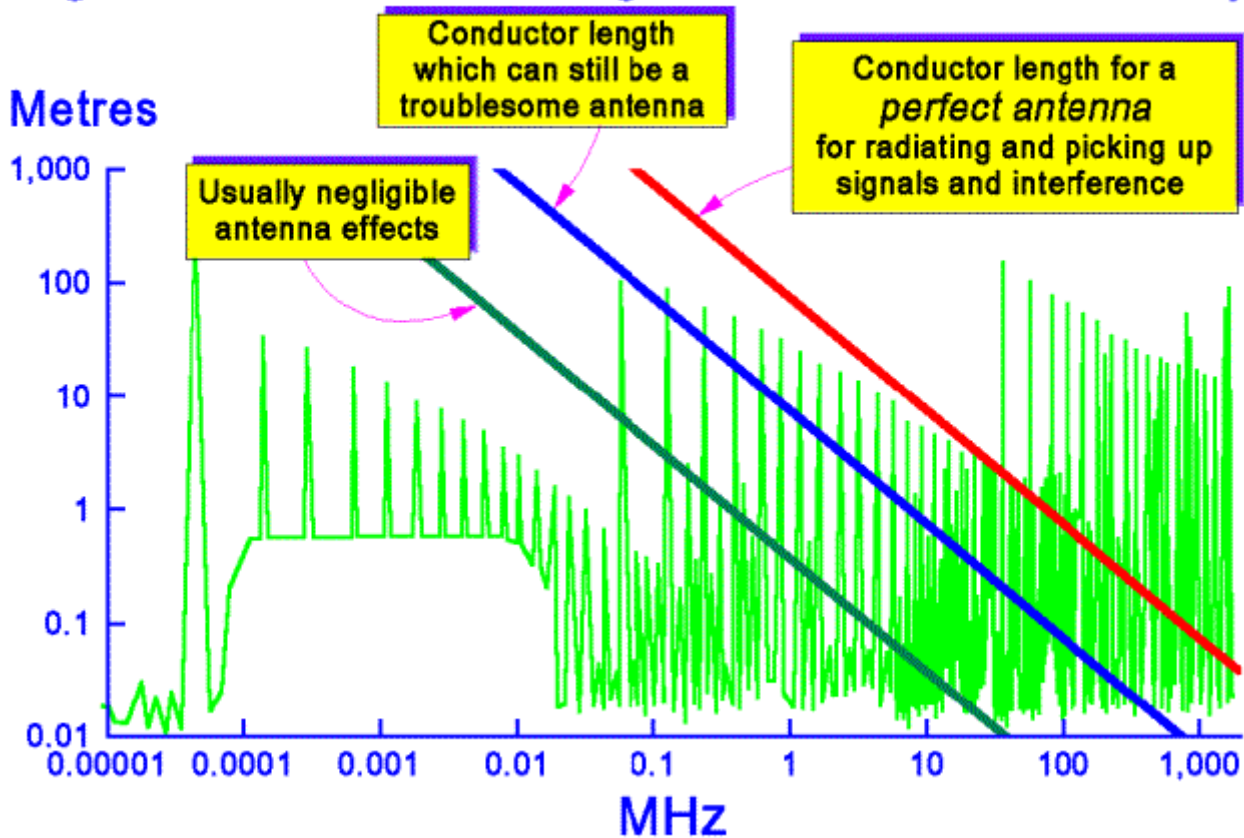
So as frequencies increase, treating conductors as merely electric or magnetic field emitters and receivers becomes inadequate, as shown by figure 2C.



Another effect of increasing frequencies is that when  $\lambda$  is comparable with conductor length, resonances occur. At some of these the conversion of signals to fields (and vice-versa) can reach almost 100%. E.g. a standard whip antenna is merely a length of wire, and is a perfect convertor of signals to fields when its length equals one-quarter of  $\lambda$ .

This is a very simplistic description, but as far as the user of cables and connectors is concerned the important thing is that all conductors can behave as resonant antennae. Obviously we want them to be very poor antennas, and assuming that a conductor is like a whip antenna (good enough for our purposes) we can use Figure 2D to help guide us.

Figure 2D Conductor length versus antenna efficiency



The vertical axis of Figure 2D is in metres of conductor length, and the spectrum of Figure 2B is retained as a visual guide. The right-hand-most (red) diagonal shows conductor length versus frequency for a perfect antenna.

Obviously, at frequencies in common use, even very short conductors can cause emissions and immunity problems. A signal or field at 100MHz finds a 1 metre long conductor to be a very efficient antenna, and at 1GHz 100mm conductors make good antennae. *This simple fact is responsible for a large number of “black magic” EMC problems.*

Not so many years ago, the frequencies in commonplace use were much lower and typical cable lengths were not very effective antennae, which is why electrical wiring “custom and practice” tends to be out of date.

The middle (blue) red diagonal in Figure 2D shows conductor lengths which do not make very efficient antennae, but can still cause problems. The left-hand (green) diagonal shows lengths which are so short that (for all except the most critical products) their antenna effects can usually be neglected.

How many times have you heard someone say: “It’s OK, I’ve earthed it.”? It is a standing joke in the EMC community that RF is colour blind, and so can’t tell that the green/yellow striped conductor they are travelling in is supposed to be a perfect earth, and consequently all earth conductors are antennas too.

### 2.3 All cables suffer from intrinsic resistance, capacitance, and inductance

Forgetting fields and antennas for a moment: a few quick-and-dirty examples will show how even very tiny departures from the ideal cause problems for signals carried by conductors at commonplace modern frequencies.

- The resistance of a 1mm diameter wire at 160MHz is 50 times more than at DC, due to the skin effect forcing 67% of the current to flow in its outermost 5 microns at that frequency.

- A 25mm long 1mm diameter wire has an intrinsic space-charge capacitance of around 1pF, which does not sound much but loads it by around 1kΩ at 176MHz. If this 25mm long piece of wire alone was driven in free space by a perfect 5V peak-to-peak 16MHz square wave, the eleventh harmonic of the 16 MHz would take 0.45mA just to drive the wire.
- A connector pin 10mm long and 1mm diameter has an intrinsic inductance around 10nH, which does not sound like much. When driven with a perfect 16MHz square wave into a backplane bus impedance that draws 40mA, the voltage drop across this pin will be around 40mV, enough to cause significant problems for signal integrity and/or EMC.
- A 1 metre long wire has an intrinsic inductance of around 1μH, preventing surge protection devices from working properly when used to connect them a building's earth-bonding network.
- A 100mm long earth wire for a filter has so much intrinsic inductance (around 100nH) that it can ruin filter performance at > 5MHz or so.
- The inductance of a 25mm long "pigtail" termination for the screen of a 4 metre cable is enough to ruin the cable's screening effectiveness at >30MHz or so.

The rules of thumb for intrinsic capacitance and inductance for wires under 2mm diameter is 1pF per inch and 1nH per mm (sorry to mix units, but they stick in the mind better). Very simple maths such as

$$Z_C = \frac{1}{\sqrt{2\pi f C}} \quad \text{and} \quad Z_L = 2\pi f L$$

found in most basic electronic textbooks allows any engineer to discover whether the intrinsic imperfections in conductors are likely to be significant.

## 2.4 Avoiding the use of conductors

The above rather hand-wavy analysis shows that cables are increasingly problematic as frequencies increase: it is difficult to get them to carry signals properly, and difficult to stop them from leaking.

Even for low-frequency signals such as audio, cables present increasing problems. Since all semiconductors act like "crystal set" detectors up to many hundreds of MHz (typical even of slow op-amps like LM324), the antenna effects of cables pollutes the audio signals unpredictably.

So the best advice on signal and data cables and connectors for the most cost-effective EMC compliance may be not use metallic conductors at all. Non-metallic communications are preferred, and there are a lot of alternatives these days, including:

- Fibre-optics (preferably metal-free)
- Wireless (e.g. Bluetooth; wireless LANs)
- Infra-red (e.g. IrDA)
- Free-space microwave and laser links (e.g. between buildings)

### 2.4.1 Cost/benefit analyses of alternatives to conductors

Many designers feel they have to keep material costs down by using traditional cables and wires. But when the overall costs of completing a project and producing reliable, EMC compliant products, systems, and installations is taken into account it is often found that a fibre-optic or wireless link would have cost less overall. By then it is too late, of course.

For signal cables and connectors: *material cost is no longer related in any predictable way to the profitable selling price*, except for the simplest of electronic products. A proper cost/benefit analysis should take account of likely problems with signal integrity and EMC compliance, risks of incurring penalty charges, plus the risks of high levels of product returns, warranty claims, and lower levels of sales due to market perception.

Design engineers prefer not to consider the commercial risks of their designs, but they are the only people able to do this with any accuracy (usually with inputs from more commercial personnel). But as long as electronic designers insist on only considering the functional performance and material costs of their designs, their companies are missing competitive advantages and suffering commercial risks of unknown size.

## 2.5 Cable segregation and routing

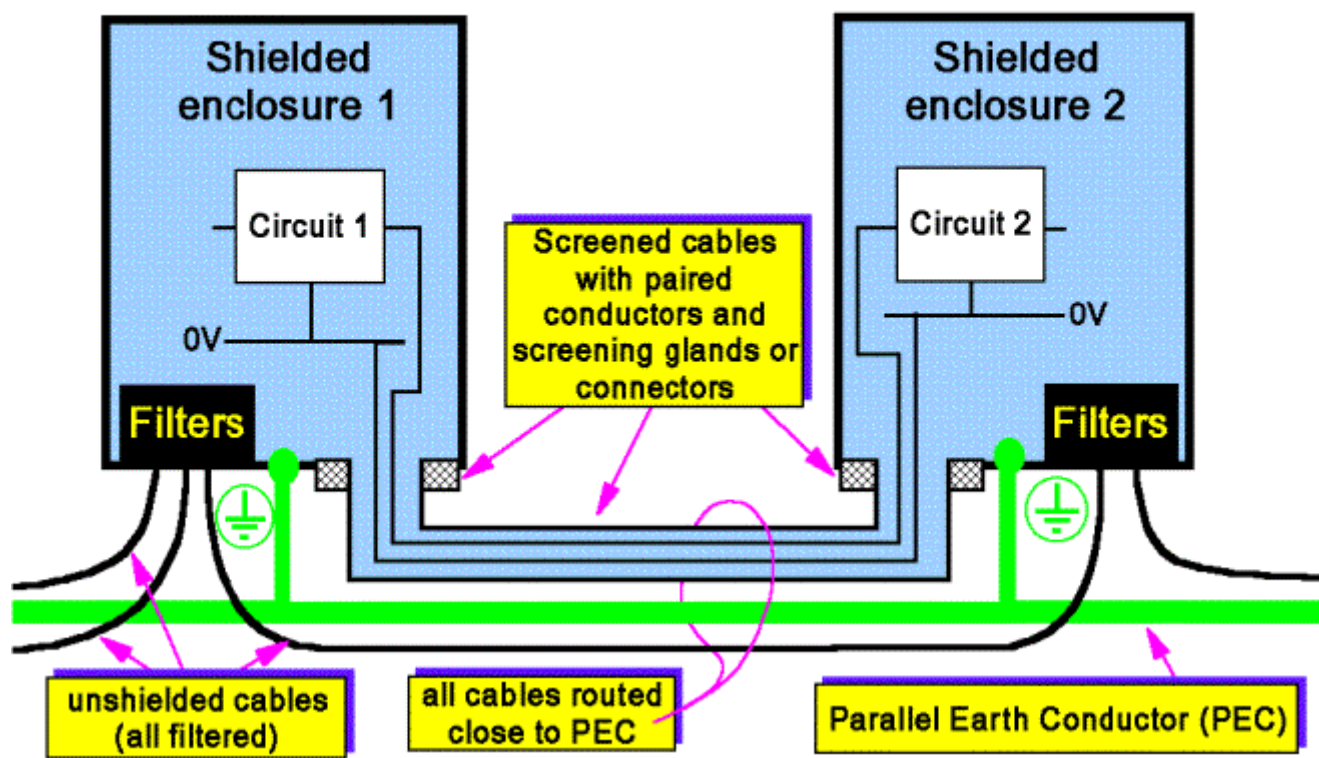
Installation cabling rules are really outside the scope of this series, but the product designer needs to know what they are so as to design his product's external connections. Here is a quick summary of the main recommendations of IEC 61000-5-2:1997 and many other recent standards concerned with the installation of information technology and telecommunications:

- a) All buildings to have a lightning protection system to BS6651 Appendix C or equivalent, bonded at ground level at least to their internal bonding network. All building steel, metalwork, cable ducts, conduits, equipment chassis, and earthing conductors in a building to be cross-bonded to create a 3-dimensional bonding network with mesh size no greater than 4 metres.
- b) Segregate power and signal cables into at least four "classes", from very sensitive to very noisy.
- c) Run all cables along a single route between items of equipment (which should therefore have a single connection panel each), whilst preserving at least minimum specified spacings between cable classes.
- d) 360° Bond cable screens (and any armouring) to the equipment enclosure shields *at both ends* (see later) unless specifically prohibited by the manufacturer of the (*proven* EMC compliant) transducer or equipment.
- e) Prevent excessive screen currents by routing all cables (signal and power) very close to conductors or metalwork forming part of the meshed earth network.
- f) Where meshed building earth is not available, use cable trays, ducts, conduits, or if these don't exist a heavy gauge earth conductor, as a Parallel Earth Conductor (PEC). A PEC must be bonded at both ends to the equipment chassis earths and the signal cable strapped to it along its entire length.

The needs for segregation, PECs, and (in general) screen bonding at both ends will have an impact on the design of interconnections panel layout, choice of connector types, and the provision of some means for bonding heavy-duty PECs.

Figure 2E gives an overview of the techniques involved in connecting screened enclosures together with both screened and unscreened cables.

Figure 2E Good practices when installing shielded enclosures



For short connections between items of equipment such as a PC and its VDU, dedicated printer, and modem, only d) above (360° cable screen bonding to enclosure shields at both ends) is needed – providing all the interconnected items are powered from the same short section of ring main, and all long cables to other parts of the building (e.g. network cables) are galvanically isolated (e.g. Ethernet). These screen bonding techniques are also needed for the EMC domestic hi-fi and home theatre systems. However, a) often comes in handy as well for protecting such equipment from damage during a thunderstorm.

## 2.6 Getting the best from cables

Open any signal cable manufacturer's catalogue and you will find a huge variety of cable types, even for similar tasks. This is a warning that cables are all imperfect. The best cable for a given application will be difficult to select, and then will probably be too expensive, too bulky, too stiff, and only available to special order on 26 week leadtime in 5km reels.

### 2.6.1 Transmission lines

Transmission line techniques prevent cables from acting as resonant antennas.

When the send and return conductors of a signal current loop are physically close together and so enjoy strong mutual coupling, the combination of their mutual capacitance and inductance results in a

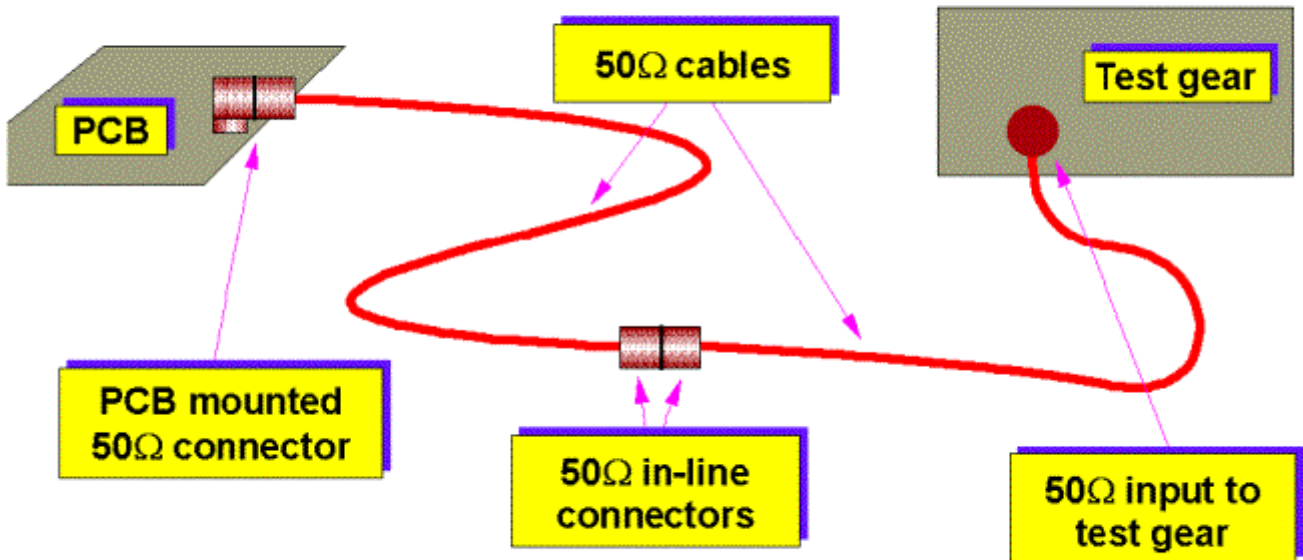
*characteristic impedance*  $Z_0 = \sqrt{\frac{L}{C}}$ , where L and C are the capacitance and inductance per unit length (a fraction of the  $\lambda$  of the highest frequency of concern).  $Z_0$  can be calculated for cables and connectors (also for PCB tracks, see Part 5 of this series).

When  $Z_0$  is kept constant over the entire length of an interconnection, and when drive and/or send (source or load) impedances are "matched" to  $Z_0$ , a controlled-impedance transmission line is created and *resonant effects do not happen*. The intrinsic inductance and capacitance of the conductors also



create far fewer problems. This is why RF and all EMC test equipment use 50Ω transmission line cables and connectors (see Figure 2F), and why high-speed and/or long distance data busses and serial communications also use transmission lines (usually in the range 50 to 120Ω).

**Figure 2F The transmission line principle familiar from standard "50Ω" test gear**

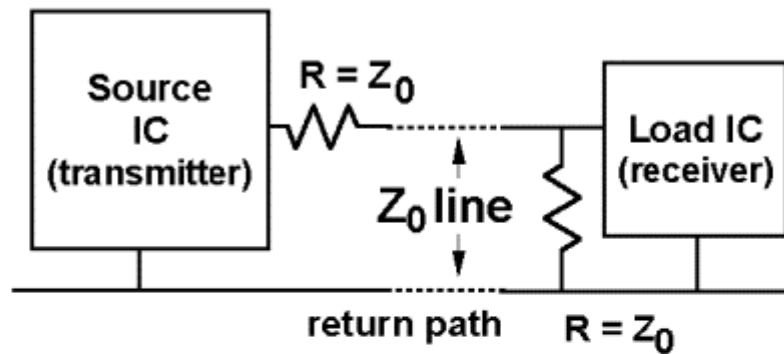


Impedances in the range 50 to 120Ω are available, especially for data communications. Manufacturers specify the impedances.

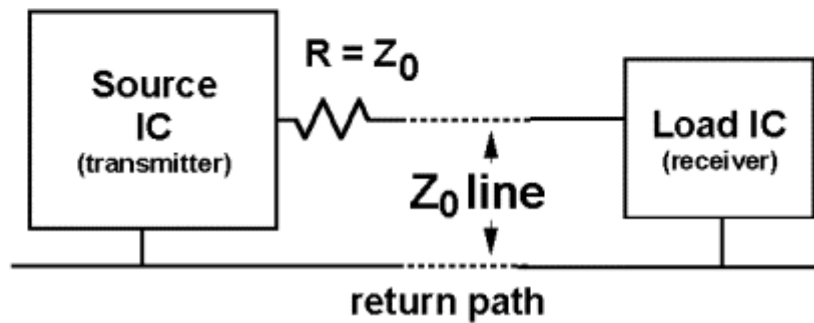
Lines must be matched, and the classical method is to match at both source and load. This provides maximum power transfer from source to load, but as it results in a 50% voltage loss for each interconnection, it is often not used for normal signal interconnections in non-RF equipment. Instead, transmission lines are often terminated at just one end, so as not to lose voltage, even though this is not ideal from either an EMC or signal integrity point of view. Terminating at one end only is a conscious decision to compromise on the engineering to save cost. Figures 2G, H, and J show the main termination methods.

**Figure 2G Transmission line terminations**

**Classic RF termination**  
best, but loses 50% voltage

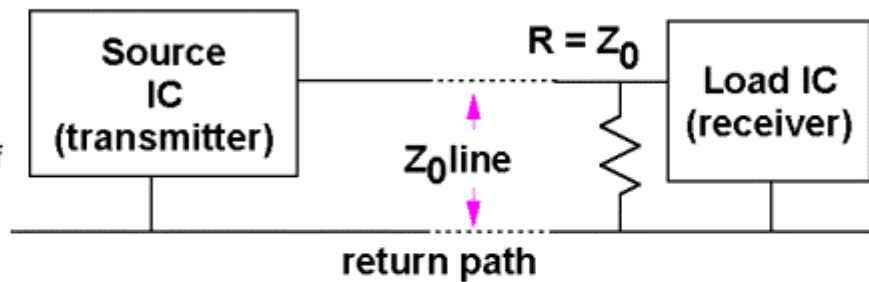


**Series (source) termination**  
low power, only for reflected wave switching

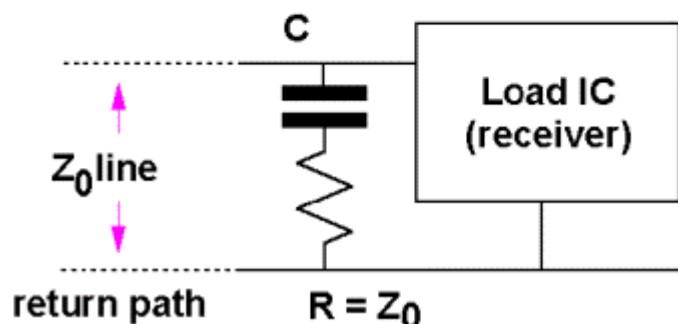


**Figure 2H Transmission line terminations continued for incident wave switching (fastest)**

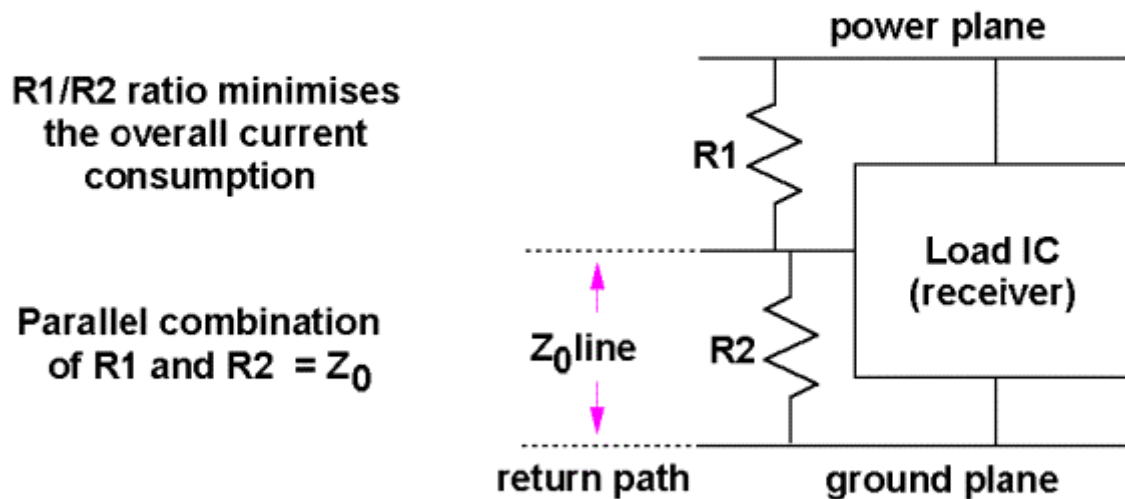
**Parallel (shunt, or load) termination**  
best, but needs a lot of power



**RC (parallel) termination**  
consumes less power



**Figure 2J Thevenin (parallel) termination for incident wave switching**



**Power plane must be bypassed to ground plane very close to R1**

But nothing is perfect and even though not resonant, even the best practical transmission lines still leak a bit. Installation also reduces transmission line performance by causing variations in  $Z_0$  (increasing leakage) when cables are bent sharply, crushed, strapped or clipped too tightly, repeatedly flexed, damaged, or fitted with inadequate connectors.

Unfortunately, the overall cost of creating transmission line cable interconnections with high enough quality at modern high frequencies can be very high. Flexible cables for microwave test equipment, for instance, can cost hundreds of pounds per metre. This is why, for GHz Ethernet to run on low-cost Cat 5 UTP (unscreened twisted pair), it has to use sophisticated DSP algorithms to reduce data rate and spread it randomly, and it still needs four pairs. So although transmission lines are very powerful, they are not a universal panacea for cable problems at high frequencies.

### 2.6.2 EMC considerations for conductors used inside and outside products

Inside a product – if the product's enclosure shields, and the screening and filtering of its external cables is good enough, almost any type of wire or cable can be used, although signal integrity will suffer. The problem here is that for high-performance digital or analogue electronics the cost of the enclosure shielding and filtering required can be so high that it would have been cheaper to use more expensive internal cables.

It is generally most cost-effective to *avoid all internal cables*, keeping all non-optical-fibre signals in the tracks of plugged-together PCBs (preferably a single PCB, even using flexi-rigid types). To make this work the PCBs need to be designed according to the Part 5 of this series, using a ground plane under all tracks. This generally reduces the cost of enclosure shielding and filtering to give the most cost-effective product, and because it also improves signal integrity it usually saves a couple of development iterations too.

Outside a product – unscreened cables with single-ended signals are now a serious liability whether the product is digital or analogue. Filtering digital signals does not help much to reduce emissions: single-ended drive produces copious common-mode currents *at the signal frequencies themselves*,

causing the product to fail conducted or radiated emissions tests depending on signal frequency. Any filtering would need to remove the signal, which does not help.

Filtering can work quite effectively for low-frequency analogue signals, but for precision beyond  $\pm 0.05\%$  (12 bits) the cost of the filter and its board area increases rapidly. Of course filters have difficulty removing in-band interference (such as powerline hum) that a properly designed balanced communication system would easily reject.

### 2.6.3 Pairing send and return conductors

Even when not using transmission lines, always use paired conductors. Provide a dedicated return path for the return current as close as possible to the send path (and not via an earth or a screen). This works even when signals are single-ended and all their return conductors are bonded to a common reference potential. The fluxcompensation effect encourages return currents to flow in the path nearest to the send conductor, in preference to alternative current paths, and we can use this natural phenomenon to help keep the field patterns of our cables tight and reduce their E and M leakages. Figure 2K shows the general principle, which is of universal application.

**Figure 2K Routing of the conductors in a cable**  
(this example is of switched circuits, but the principle is universally applicable)

**It is bad practice to run the return path differently from send path**  
– always use paired send and return conductors which are physically close

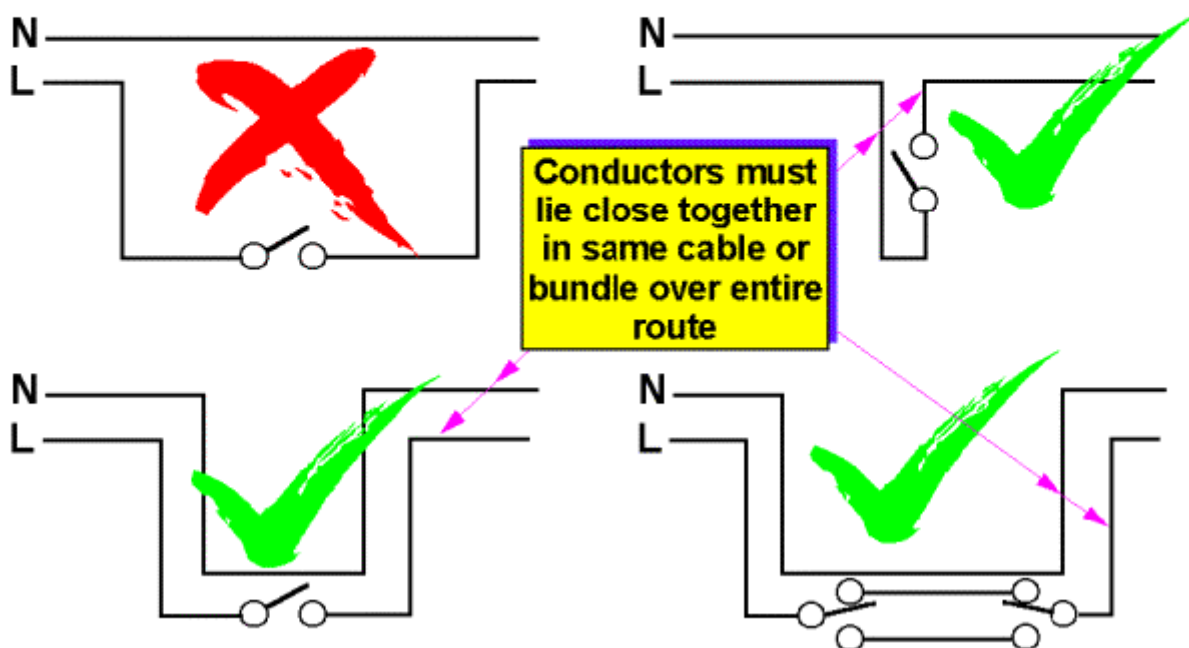


Figure 2K shows a mains supply with a switch in one line, but the same principle applies to signals.

The closeness of the send and return conductors over the entire current loop is absolutely crucial at the highest frequencies for circuits to work at all, never mind good EMC.

Ribbon cables carrying a number of single-ended (i.e. 0V referenced) signals are very poor indeed for EMC and signal integrity, but screening them results in stiff, bulky, expensive cable assemblies which is what flat cables were supposed to avoid.

Using the pairing technique for flat cables improves their EMC considerably and this conductor arrangement is the best:

*return, signal, return, signal, return, etc.*

A less effective alternative which is often recommended is:

*return, signal, signal, return, signal, signal, return*, etc.

Significant improvements can often be made by fitting flat cable ferrite clamps (common-mode chokes) at the source end(s), so that the conductor pairs behave as if they were driven from a balanced source at high frequencies, although proper balanced drive/receive circuits are better (see Part 1 of this series).

Twisted pairs are very much better than parallel pairs. Use twisted triples, quads, etc. where this is what it takes to get all the send and return paths of a signal in close proximity.

Twisted send and return conductors are strongly recommended for power cables: combining all phase and neutral conductors (two for single-phase, three for three-phase, four for three-phase plus neutral) in a single cable with a slow twist greatly reduces the emissions of powerline M field emissions. M fields from power busbars or individually routed phase and neutral cables can render whole areas of buildings unfit for CRT-based VDU monitors.

Twisted pairs using balanced circuitry (see Part 1 of this series) and common-mode chokes can be good for signals up to some tens of MHz, depending on the “balance” of the circuit, cable, and connectors. Any unbalance will convert some of the wanted signal into useless common-mode currents, which all leaks away as fields. Just a few micro-amps of common-mode can fail an emissions test. Tighter and more precisely regular twists make cables better for higher frequencies.

A great many types of twisted-pair cables are available, some intended for transmission lines ( $Z_0$  will be specified). But twisted pair technology does not suit mass-termination. So-called “twist + flat” flat cable has multiple twisted pairs all formed into a ribbon, but has regular lengths of 100mm or so of parallel conductors for mass-terminating connectors – and the flat bits are so long they compromise EMC.

#### **2.6.4 Getting the best from screened cables: the screen**

There is no such thing as a cable that “complies with the EMC Directive”, there are only cables with frequency-dependant screening performance.

Cable screens must cover the entire route with 360° coverage. Making screening work effectively with low-cost these days is increasingly difficult, except for the least aggressive *and* least sensitive signals.

*It is no longer best practice to use the shield of a cable as the signal return.* The problem with co-axial cables is that the screen carries currents for both the signal return and external interference, and they use the skin effect to keep them on different sides of the screen (known as “tri-axial mode”). This works fine for solid copper screens (plumbing, to you and me), but flexible screened cables aren’t very good at keeping the two currents apart, so return currents leak out, and interfering currents leak in.

But (I hear you say) all RF test equipment uses flexible co-ax, so it must be OK. Look carefully at these cables next time you are in an EMC test lab: the cables used for higher frequencies are very thick, stiff, and expensive, partly because they are double-screened at least. They use expensive screwed connectors (e.g. N-types), and are always used in matched (at both ends) 50Ω transmission lines. They are also treated reverentially and woe betide you if you tread on one. At higher frequencies than the average EMC test lab, semi-rigid or rigid co-axial cables have to be used, as stiff as automotive brake pipes.

The ability of a screened cable to prevent interference is measured in two ways, as shielding effectiveness (SE), and also as  $Z_T$ . SE seems obvious enough, and  $Z_T$  is simply the ratio of the voltage which appears on the centre conductor in response to an external RF current injected into the screen. For a high SE at a given frequency, we need a low  $Z_T$ . A flat  $Z_T$  of a few milliΩ over the whole frequency range would be ideal.

A very broad-brush summary of the screening qualities of typical types of screened cables follows, but remember that within each broad category there are many different makes and grades with different performances:

- Spiral wrapped foil is not terribly good at any frequency, and gets progressively worse > 1MHz.
- Longitudinal foil wrap is better than spiral foil.
- Single braid is better than foil at all frequencies, but still gets progressively worse > 10MHz.
- Braid over foil, double braid, or triple braid, are all better than single braid and all start to get progressively worse >100MHz
- Two or more insulated screens are better still, but only up to about 10MHz, at higher frequencies resonances between the screens can reduce their effectiveness to that of just one screen at some frequencies.
- Solid copper screens (e.g. semi-rigid, rigid, plumbing) are better than braid types and *their screening performance continually improves at higher frequencies*, unlike braid or foil, which always degrades above some frequency.  
Round metal conduit can be used to add a superb high-frequency performance screen. (Armouring is also useful as a screen but only at low frequencies, say up to a few MHz.)
- “Superscreened” cables use braid screens with a MuMetal or similar high-permeability wrap. These can be as good or even better than a solid copper screen, whilst still retaining some flexibility, but are expensive and suit applications where performance is more important than price (e.g. aerospace, military).
- I’m only aware of one manufacturer (Eupen) offering ferrite-loaded screened cables, which may offer improved high-frequency performance with good flexibility without the high cost of superscreened cables.

To reduce the bulk and cost of our screened cables and still get good EMC for high-performance modern products we need to use paired conductors for every signal and its return, preferably twisted pairs, just as described above for unscreened cables. Balanced drive/receive is also a great help.

### 2.6.5 Getting the best from screened cables: terminating the screen

Using co-axial cables and connecting their screens to a circuit 0V track is almost a guarantee of EMC disaster for high-performance digital and analogue products, for both emissions and immunity. Insulated BNC connectors on a product are usually a sign that all may not be well for EMC.

Cable screens should always be connected to their enclosure shield (even if they then go on to connect to circuit 0V), unless there are very good quantitative engineering and EMC reasons why not. “We’ve always done it this way” is not a reason.

Circuit development benches need to create the real structure of the product and the real interconnections with the outside world as closely as possible. Otherwise circuit designers may use various interconnection tricks to make their PCBs test well on the bench (I know, I used to do it too) – leaving it to someone else to sort out the resulting real-life application and EMC problems.

But even a high-quality screened cable is no good if the connection of the screen to the product is deficient. Cable screens need to be terminated in 360° – a complete circumferential connection to the skin of the screened enclosure they are penetrating, so the connectors used are very important.

“Pigtails” should never be used, except where the screen is only needed up to a couple of MHz. Where pigtails are used they must be kept as short as assembly techniques allow, and splitting a pigtail into two on opposite sides also helps a bit. In the mid 1980’s a company replaced all their pigtailed chassis-mount BNCs with crimped types for EMC reasons. Although the crimping tool cost around £600 they were surprised to find they quickly saved money because crimping was quicker and suffered fewer rejects. So pigtailing may be uneconomic as well as poor for EMC.

The “black magic” of cable screening is to understand that a cable’s SE is compromised if its connectors, or the enclosure shields it is connected to, have a lower SE.

It is possible to use screened cables successfully with some unshielded products, if they use no internal wires and their PCBs are completely ground-planed with low-profile components. This is because the PCB ground plane, like any metal sheet, creates a zone of reduced field strength – a volumetric shield for a limited range of frequencies. Successful use of this technique depends upon

the electronic technology in the product, and is unlikely to be adequate for high-performance digital or analogue products. The cable screens would connect 360° to the PCB ground plane.

### 2.6.6 Terminating cable screens at both ends

This seems like heresy to some, but with the high frequencies in use these days leaving an end unterminated will usually leak too much. Screen termination at both ends also allows the screen to work on all orientations of magnetic fields.

Of course, connecting screens at both ends allows any earth potential differences to drive currents in the screen that might cause hum pickup, and even melt the cables. Where such earth currents exist it is an indication of poor facility earth-bonding which could allow earth faults or thunderstorm surges to destroy inadequately protected electronics. It is not unknown for screened cables to flash-over at unterminated ends during thunderstorms, creating obvious hazards.

It is sometimes recommended to electrically bond a cable screen at one end, and terminate the other with a small capacitor. The aim is to prevent excessive power frequency screen currents, and it does work to some extent although it is difficult to get capacitors to provide low enough inductance for very high frequencies and it does nothing for surge and flashover problems. Insulated BNC connectors are available with screen-to-chassis capacitors built-in, but the last price I had for types which worked well to 1GHz was nearly £20 each.

Galvanically isolated communications offer a way out of bonding screens at both ends, but such an approach needs careful attention to detail, especially the safety and reliability issues associated with installation earth-faults and surges. Metal-free fibre optics are the best kind of galvanically-isolated signal communications, and the easiest to use.

Section 2.5 above briefly lists the currently accepted best installation practices in achieving good EMC (e.g. using a PEC to divert heavy earth currents) *without* suffering hot cables *and* without compromising safety. Refer to IEC 61000-5-2:1997 for more detail.

## 2.7 Getting the best from connectors

Connectors suffer from many of the same EMC problems as cables, after all, they are just short lengths of conductor in a rigid body.

It is best to segregate connectors into those used for internal connections, and those used for outside connections, because of the possibility of flashover from outside to inside pins during surge or electrostatic discharge events. Such flashovers can bypass protective devices.

### 2.7.1 Unscreened connectors

Controlled-impedance transmission-line connectors are increasingly available for high-speed backplanes or cables.

When not using transmission lines, much improved EMC and signal integrity can be had from ordinary multiway connectors (e.g. DIN41612, screw-terminal strips) by making sure that each “send” pin has a return pin alongside. At the very least provide one return pin for every two signals. It is best when these are used with balanced signals, but the technique also helps when signals are single-ended.

### 2.7.2 Connectors between PCBs

Connectors between PCBs (e.g. daughterboard to motherboard) also benefit greatly from multiple 0V pins spread over their full length and width, and a similar arrangement of power pins also helps significantly. Optimum signal integrity and EMC is generally achieved (for signals sharing the same power rails) with a pin pattern that goes:

0V, signal, +V, 0V, signal, +V, 0V, signal, +V, 0V, etc.

The following pattern provides lower performance but is often adequate, and uses fewer pins:

0V, signal, +V, signal, 0V, signal, +V, signal, 0V, etc.

It is also best to extend the connector over the full length of the common edge between the two boards, and liberally sprinkle 0V and power connections over the full length. There is some evidence

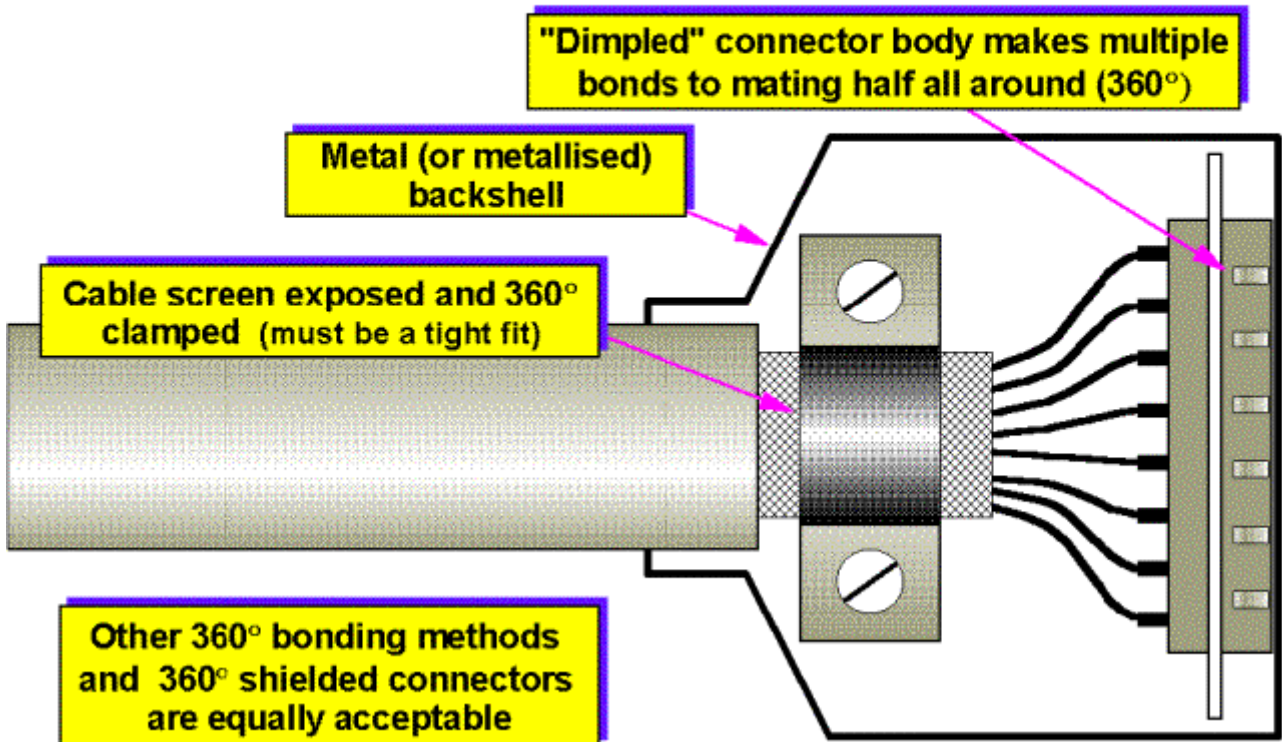
that random pin allocations may provide better performance by breaking up standing wave patterns. Additional grounds between sensitive and noisy signals can help be a barrier to crosstalk.

We don't really like connectors on PCBs, and they should be avoided if possible (reliability will improve as a result) – as mentioned earlier, single or flexi-rigid PCBs with ground planes under all their tracks are better. Also: don't socket ICs (use field programmable PROMS). Each IC socket pin is a little antenna positioned right at the most vulnerable or noisy location possible.

### 2.7.3 Screened connectors

There is no such thing as a connector that "complies with the EMC Directive", there are only connectors with frequency-dependant screening performance. Screened cables must maintain 360° screen coverage over their whole length, including the backshells of their connectors at both ends. Connector backshells must make 360° electrical bonds to the enclosure shields they are mounted on, using iris springs or some other method. Saddle-clamps seem to make adequate screen bonds for most purposes in rectangular connector backshells, but avoid the ones that need the screen to be made into a pigtail, however short. Figure 2L shows a typical D-type screen termination.

**Figure 2L Example of 360° termination of cable screen in connector backshell (D-type shown)**



Co-axial and twinaxial screened cables benefit most from connectors with screwed metal backshells. These are better and more reliable at high frequencies than bayonet types (like BNC), which is why they are used on satellite TV convertor boxes.

Multiway screened cables are also best used with round connectors with screwed backshells, but are often specified with rectangular connectors such as D-types or larger. Making a 360° connection from cable screen to connector backshell, and from backshell to enclosure shield, seems a lot to ask of some connector manufacturers, so check this has been done effectively before committing to a particular make or type. Especially watch out for single (or long) springs, clips, and wires, when used to make a screen bond: these are just pigtails and will limit SE at high frequencies.

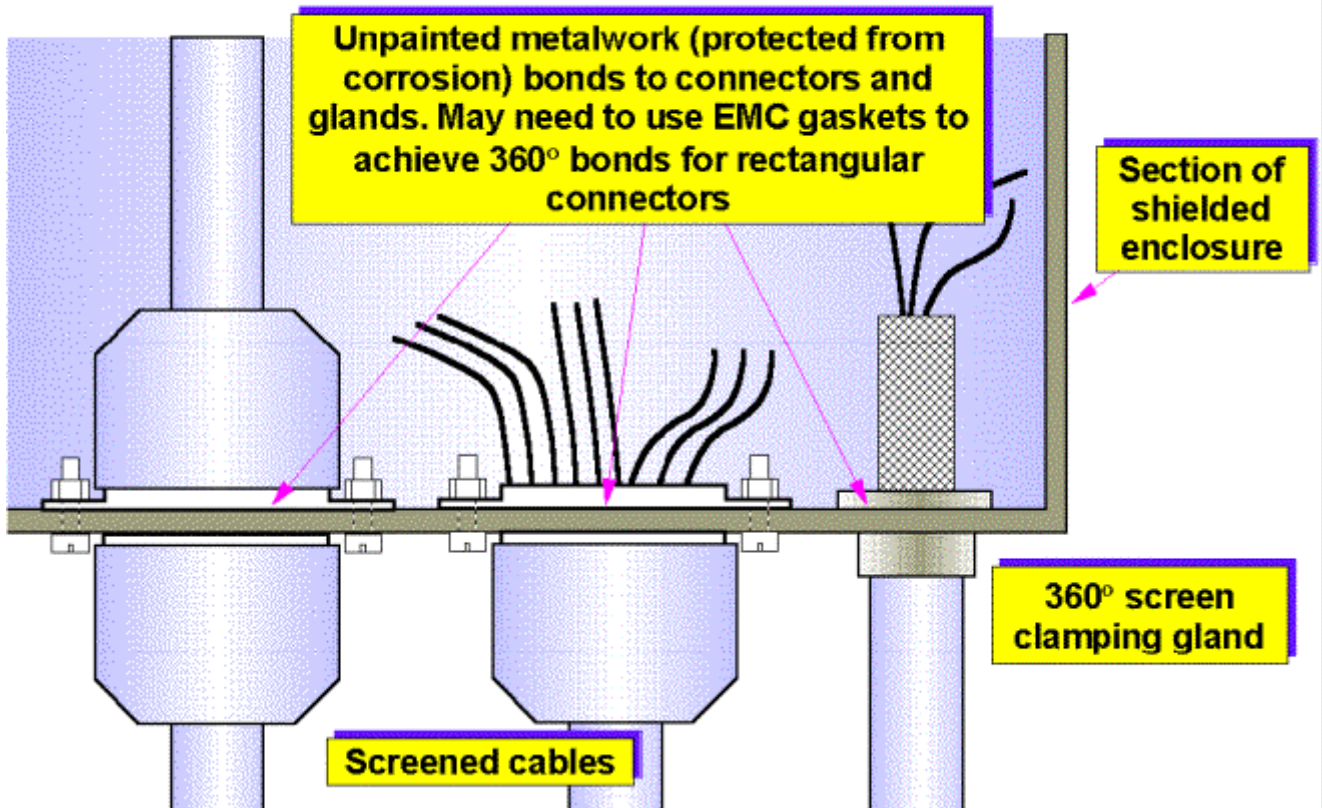
Unfortunately, many industry-standard connectors do not allow correct termination of cable shields (e.g. jack plugs, XLRs, phonos, and any number of proprietary connector models). Also unfortunately,



connector systems are still being designed without adequate thought being given to the need for simple 360° cable screen termination (e.g. RJ45, USB). The overall SE of a connector will be compromised if used with an enclosure shield or cable with a lower SE.

Figure 2M shows some of the important considerations when bonding connectors to shielded enclosures.

**Figure 2M Cable screens entering a shielded cabinet**



## 2.8 Further reading

There is a great deal more on cabling for EMC in the following:

Tim Williams, *EMC for Product Designers* 3<sup>rd</sup> edition, Newnes 2001, ISBN: 0-7506-4930-5, [www.newnespress.com](http://www.newnespress.com)

IEC 61000-5-2:1997 Electromagnetic Compatibility (EMC) – Part 5: Installation and mitigation guidelines – Section 2: Earthing and cabling, [www.iec.ch](http://www.iec.ch).

Tim Williams and Keith Armstrong, *EMC for Systems and Installations*, Newnes 2000, ISBN 0 7506 4167 3 [www.newnespress.com](http://www.newnespress.com), RS Components Part No. 377-6463.

Keith Armstrong, *EMC for Systems and Installations – Parts 1 through 6*, EMC+Compliance Journal, 2000. All UK EMC Journal and EMC+Compliance Journal articles are available electronically from the magazine archive at [www.compliance-club.com](http://www.compliance-club.com).

*Eur Ing Keith Armstrong CEng MIEE MIEEE*

Partner, Cherry Clough Consultants, [www.cherryclough.com](http://www.cherryclough.com), Associate of EMC-UK

Phone: 01457 871 605, Fax: 01457 820 145, Email: [keith.armstrong@cherryclough.com](mailto:keith.armstrong@cherryclough.com)